

# STATIONARY DUMPERS

1,000/2,000/4,000/6,000 LBS

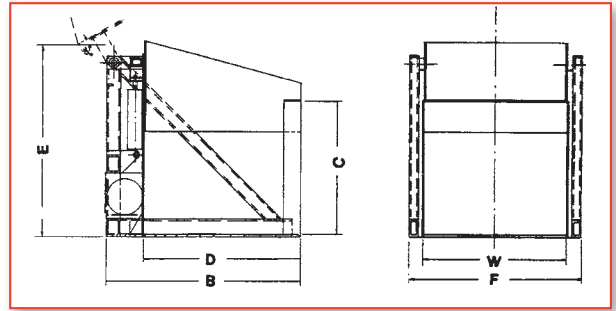
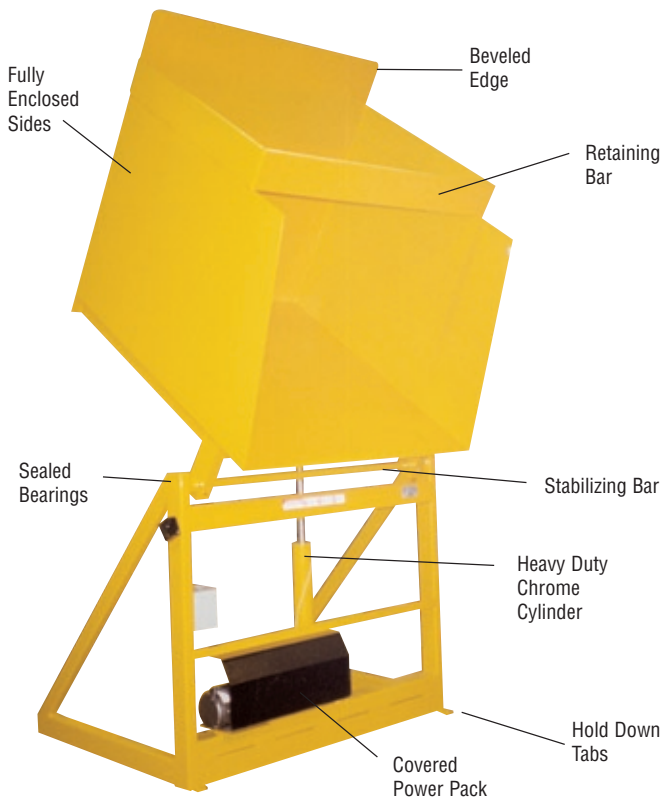

## CAPACITY

- 1,000/2,000/4,000/6,000 lbs.

## BASE SIZES

- 48" wide x 36" long  
and 50" wide x 50" long

## DUMPING ANGLE

- 0° - 120°

## RETAINING BAR

- Fixed bar - mounted 3" above container height, located above opening
- Spring loaded bar available for multiple container heights (optional)

## SAFETY

- Velocity fuse is standard on each cylinder to eliminate dumpers from collapsing due to hose failure
- Hold down tabs in each corner
- Flow control and pressure equalizing valve built in each pump
- Fully enclosed sides to give the dumper stability, avoid spillage and funnel product

## POWER SUPPLIES

A/C 110/1/60 volt (standard)

Hand held (standard)

Foot control (optional)

A/C 220-460-575/3/60 volt

Hand or foot controlled (optional)

Air/Hydraulic

Foot control (standard)

Hand control (optional)

## OPTIONS

- Larger/smaller platform sizes
- Increase/reduce pump height
- Portability
- Limit switchcases
- Special electrical controls
- Chute attachments
- Galvanized, stainless steel, "Steel It" epoxy paint
- Stands for higher dumping applications
- Side guards

## STATIONARY DUMPER

MODEL NO.	CAPACITY (LBS.)	PLAT. SIZES (W x D) (IN.)	DUMP HEIGHT (E) (IN.)	TILT ANGLE	R'TEG BAR (C) (IN.)	OVERALL DIM. (F x B) (IN.)
<b>DUMP HEIGHT 36"</b>						
SD 36-10	1,000	48 x 36	36	0 - 120°	UP TO 40	54 x 52
		50 x 50	36	0 - 120°	UP TO 40	56 x 66
SD 36-20	2,000	48 x 36	36	0 - 120°	UP TO 40	54 x 52
		50 x 50	36	0 - 120°	UP TO 40	56 x 66
SD 36-40	4,000	48 x 36	36	0 - 120°	UP TO 40	54 x 52
		50 x 50	36	0 - 120°	UP TO 40	56 x 66
SD 36-60	6,000	48 x 36	36	0 - 120°	UP TO 40	54 x 52
		50 x 50	36	0 - 120°	UP TO 40	56 x 66
<b>DUMP HEIGHT 48"</b>						
SD 48-10	1,000	48 x 36	48	0 - 120°	UP TO 48	54 x 52
		50 x 50	48	0 - 120°	UP TO 48	56 x 66
SD 48-20	2,000	48 x 36	48	0 - 120°	UP TO 48	54 x 52
		50 x 50	48	0 - 120°	UP TO 48	56 x 66
SD 48-40	4,000	48 x 36	48	0 - 120°	UP TO 48	54 x 52
		50 x 50	48	0 - 120°	UP TO 48	56 x 66
SD 48-60	6,000	48 x 36	48	0 - 120°	UP TO 48	54 x 52
		50 x 50	48	0 - 120°	UP TO 48	56 x 66
<b>DUMP HEIGHT 60"</b>						
SD 60-10	1,000	48 x 36	60	0 - 120°	UP TO 60	54 x 52
		50 x 50	60	0 - 120°	UP TO 60	56 x 66
SD 60-20	2,000	48 x 36	60	0 - 120°	UP TO 60	54 x 52
		50 x 50	60	0 - 120°	UP TO 60	56 x 66
SD 60-40	4,000	48 x 36	60	0 - 120°	UP TO 60	54 x 52
		50 x 50	60	0 - 120°	UP TO 60	56 x 66
SD 60-60	6,000	48 x 36	60	0 - 120°	UP TO 60	54 x 52
		50 x 50	60	0 - 120°	UP TO 60	56 x 66

See page 29 for options available.

# STATIONARY DUMPERS

1,000/2,000/4,000/6,000 LBS

## OPTIONS



PORTABLE DUMPER W/  
ADJUSTABLE  
RETAINING BAR



PORTABLE DUMPER W/  
NARROW  
DISCHARGE CHUTE



SAFETY GATE  
WITH LOCK OUT



STATIONARY DUMPER  
W/STAINLESS DISCHARGE CHUTE  
& SPECIAL RETAINING SCREEN



STATIONARY DUMPER WITH  
ADJUSTABLE CHUTE ATTACHMENT  
AND SAFETY SKIRTING



PORTABLE FORK  
OVERARM DUMPER

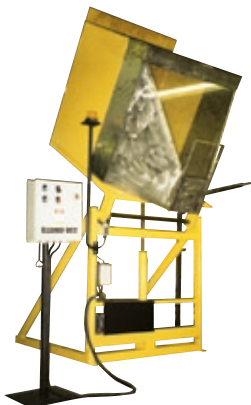

FULLY AUTOMATED DUMPER  
WITH MANUAL OVER RIDE  
AND "E" STOP



STATIONARY DUMPER  
W/ADJUSTABLE  
RETAINING BAR



SIDE LOADING DUMPER



WHEELED CART DUMPER



"STEEL-IT" PAINTED FOOD  
GRADE DUMPER



STAINLESS STEEL DOUGH  
TROUGH DUMPER



STATIONARY FORK OVERARM  
DUMPER FOR DUMPING  
PORTABLE CONTAINERS



PORTABLE STAINLESS STEEL  
"V" MAG DUMPER



GALVANIZED DUMPER  
WITH STAINLESS CHUTE



STAINLESS STEEL  
DUMPER



Stainless Glass Bead Finish



STATIONARY DUMPER  
WITH HYDRAULIC GATES

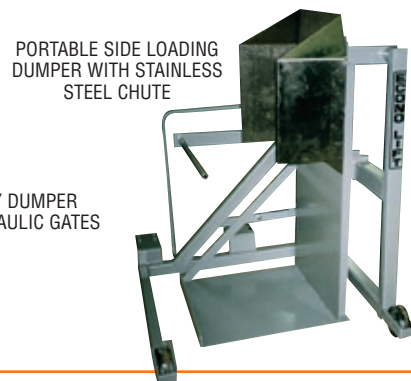

PORTABLE SIDE LOADING  
DUMPER WITH STAINLESS  
STEEL CHUTE



STATIONARY  
CONVEYOR  
DUMPER



PORTABLE CONVEYOR  
DUMPER WITH CHUTE