

DOUBLE SCISSOR LIFT TABLES

500 / 1,000 / 1,500 / 2,000 / 4,000 / 5,000 / 6,000 LBS



LIFT & TILTS

LIGHT DUTY DOUBLE SCISSOR LIFT

MODEL NO.	CAPACITY (LBS.)	STD. PLAT. BASE (W x L) (IN.)	OVERSIZED PLATFORMS (UP TO) (IN.)	LOW HT (LH) (IN.)	RAISED HT (TH) (IN.)	UP SPEED (SEC.)	MOTOR (H.P.)	VOLT/HP/HZ	SHIP WEIGHT (LBS.)
LDSL30-5-12*	500	12 x 24	12 x 24	6	36	20	1/2	115/1/60	185
LDSL30-5-16	500	16 x 24	24 x 36	6	36	20	1/2	115/1/60	210
LDSL30-10	1,000	16 x 24	24 x 36	6	36	20	1/2	115/1/60	210
LDSL36-15	1,500	16 x 36	30 x 48	6	42	25	3/4	115/1/60	220

*Power pack external **

STANDARD 24" WIDE BASE DOUBLE SCISSOR LIFT TABLES

MODEL NO.	CAPACITY (LBS.)	STD. PLAT. BASE (W x L) (IN.)	OVERSIZED PLATFORMS (UP TO) (IN.)	LOW HT (LH) (IN.)	RAISED HT (TH) (IN.)	UP SPEED (SEC.)	MOTOR (H.P.)	VOLT/HP/HZ	SHIP WEIGHT (LBS.)
48" TRAVEL - 24" WIDE x 36" LONG PLATFORM/BASE									
DSL48-10	1,000	24 x 36	48 x 60	12	60	18	1	115/1/60	625
DSL48-15	1,500	24 x 36	48 x 60	12	60	20	1	115/1/60	650
DSL48-20	2,000	24 x 36	48 x 60	12	60	30	1	115/1/60	675
DSL48-30	3,000	24 x 36	48 x 60	16	64	40	1	115/1/60	695
DSL48-40	4,000	24 x 36	48 x 60	16	64	55	1	115/1/60	725
DSL48-50	5,000	24 x 36	48 x 60	16	64	40	1	208, 220, 460, 575/3/60	750
DSL48-60	6,000	24 x 36	48 x 60	16	64	55	1	208, 220, 460, 575/3/60	780
72" TRAVEL - 24" WIDE x 48" LONG PLATFORM/BASE									
DSL72-10	1,000	24 x 48	48 x 72	12	84	20	1	115/1/60	850
DSL72-15	1,500	24 x 48	48 x 72	12	84	22	1	115/1/60	875
DSL72-20	2,000	24 x 48	48 x 72	12	84	32	1	115/1/60	900
DSL72-30	3,000	24 x 48	48 x 72	16	88	44	1	115/1/60	930
DSL72-40	4,000	24 x 48	48 x 72	16	88	60	1	115/1/60	975
DSL72-50	5,000	24 x 48	48 x 72	16	88	49	1	208, 220, 460, 575/3/60	1,000
DSL72-60	6,000	24 x 48	48 x 72	16	88	57	1	208, 220, 460, 575/3/60	1,050

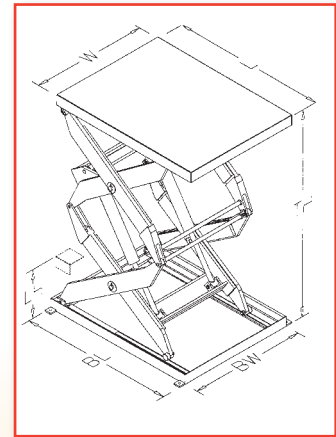

OPTIONS

- Oversized platforms
- Beveled edges for pit mounting
- Eye-bolts for pit mounting
- Rotating tops
 - spring detents
 - manual detents
- Roller conveyor, Ball transfer tops
- Bellow safety skirting
- Safety tape switch
- Semi-portable
- Portable

SPECIFICATIONS - wide based units; for wider platform applications and greater stability.

36" WIDE BASE DOUBLE SCISSOR LIFT TABLES

MODEL NO.	CAPACITY (LBS.)	STD. PLAT. BASE (W x L) (IN.)	OVERSIZED PLATFORMS (UP TO) (IN.)	LOW HT (LH) (IN.)	RAISED HT (TH) (IN.)	UP SPEED (SEC.)	MOTOR (H.P.)	VOLT/HP/HZ	SHIP WEIGHT (LBS.)
48" TRAVEL - 36" WIDE x 36" LONG PLATFORM/BASE									
3DSL48-10	1,000	36 x 36	60 x 60	12	60	18	1	115/1/60	650
3DSL48-15	1,500	36 x 36	60 x 60	12	60	20	1	115/1/60	675
3DSL48-20	2,000	36 x 36	60 x 60	12	60	30	1	115/1/60	700
3DSL48-30	3,000	36 x 36	60 x 60	16	64	40	1	115/1/60	725
3DSL48-40	4,000	36 x 36	60 x 60	16	64	55	1	115/1/60	750
3DSL48-50	5,000	36 x 36	60 x 60	16	64	40	1	208, 220, 460, 575/3/60	775
3DSL48-60	6,000	36 x 36	60 x 60	16	64	55	1	208, 220, 460, 575/3/60	800
72" TRAVEL - 36" WIDE x 48" LONG PLATFORM/BASE									
3DSL72-10	1,000	36 x 48	60 x 72	12	84	20	1	115/1/60	875
3DSL72-15	1,500	36 x 48	60 x 72	12	84	22	1	115/1/60	900
3DSL72-20	2,000	36 x 48	60 x 72	12	84	32	1	115/1/60	925
3DSL72-30	3,000	36 x 48	60 x 72	16	88	44	1	115/1/60	950
3DSL72-40	4,000	36 x 48	60 x 72	16	88	60	1	115/1/60	995
3DSL72-50	5,000	36 x 48	60 x 72	16	88	49	1	208, 220, 460, 575/3/60	1,050
3DSL72-60	6,000	36 x 48	60 x 72	16	88	57	1	208, 220, 460, 575/3/60	1,095

48" WIDE BASE DOUBLE SCISSOR LIFT TABLES

MODEL NO.	CAPACITY (LBS.)	STD. PLAT. BASE (W x L) (IN.)	OVERSIZED PLATFORMS (UP TO) (IN.)	LOW HT (LH) (IN.)	RAISED HT (TH) (IN.)	UP SPEED (SEC.)	MOTOR (H.P.)	VOLT/HP/HZ	SHIP WEIGHT (LBS.)
48" TRAVEL - 48" WIDE x 36" LONG PLATFORM/BASE									
4DSL48-10	1,000	48 x 36	72 x 60	12	60	18	1	115/1/60	875
4DSL48-15	1,500	48 x 36	72 x 60	12	60	20	1	115/1/60	900
4DSL48-20	2,000	48 x 36	72 x 60	12	60	30	1	115/1/60	925
4DSL48-30	3,000	48 x 36	72 x 60	16	64	40	1	115/1/60	950
4DSL48-40	4,000	48 x 36	72 x 60	16	64	55	1	115/1/60	995
4DSL48-50	5,000	48 x 36	72 x 60	16	64	40	1	208, 220, 460, 575/3/60	1,050
4DSL48-60	6,000	48 x 36	72 x 60	16	64	55	1	208, 220, 460, 575/3/60	1,095
72" TRAVEL - 48" WIDE x 48" LONG PLATFORM/BASE									
4DSL72-10	1,000	48 x 48	72 x 72	12	84	20	1	115/1/60	1,050
4DSL72-15	1,500	48 x 48	72 x 72	12	84	22	1	115/1/60	1,100
4DSL72-20	2,000	48 x 48	72 x 72	12	84	32	1	115/1/60	1,195
4DSL72-30	3,000	48 x 48	72 x 72	16	88	44	1	115/1/60	1,295
4DSL72-40	4,000	48 x 48	72 x 72	16	88	60	1	115/1/60	1,400
4DSL72-50	5,000	48 x 48	72 x 72	16	88	49	1	208, 220, 460, 575/3/60	1,450
4DSL72-60	6,000	48 x 48	72 x 72	16	88	57	1	208, 220, 460, 575/3/60	1,495

DOUBLE SCISSOR LIFT TABLES

500/1,000/1,500/2,000/3,000/4,000/5,000/6,000 LBS



Heavy Duty Cylinders with Chrome Plated Rams and Polyurethane Seals

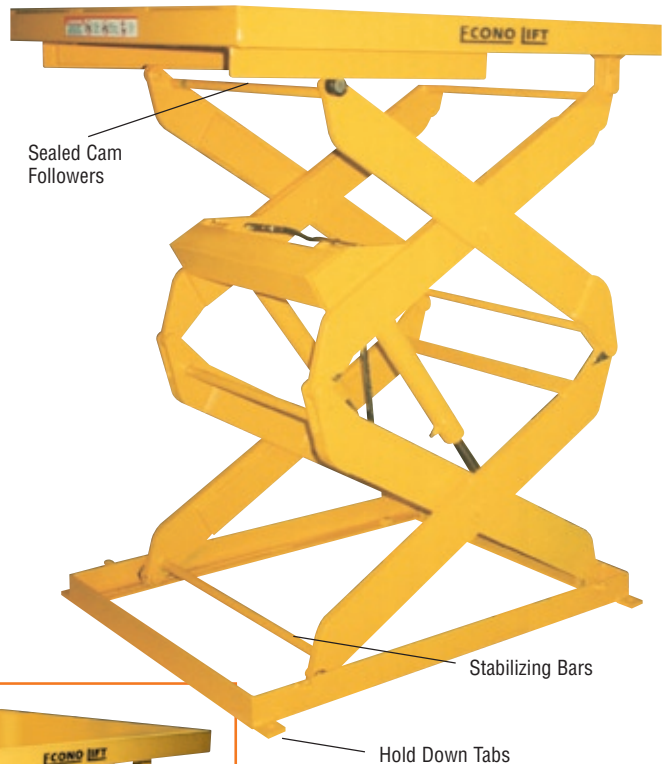

Sealed Cam Followers

Stabilizing Bars

Hold Down Tabs



CAPACITY

- 1,000/1,500/2,000/3,000/4,000/5,000/6,000 lbs.

PLATFORM SIZES

- 24" wide x 36" long to 72" wide x 72" long

BASE SIZES

- Standard 24", 36", 48" wide x 36", 48" long

TRAVEL

- 48", 72" vertical travel

LOWERED HEIGHTS

- 12", 18"

SAFETY

- Velocity fuse is standard on each cylinder
- Heavy duty hydraulic cylinders - chrome plated rod with polyurethane seals

POWER SUPPLIES

- A/C 110/1/60 volt (standard)
Hand or foot operated
- A/C 460/575/3/60 volt (opt.)
Hand or foot operated
- Air/Hydraulic
Foot operated (standard)
Hand operated (optional)

- Internally mounted
- Easily accessible for maintenance or repair
- Motors - Single phase 1 h.p. and three phase 1-1/2 h.p. - hand or foot operated standard

MAINTENANCE

- Hinged table top provides easy access to power unit and cylinders
- Self lubricated bronze bushings on all wear points

OPTIONS

Portable D/C Battery Double Scissor Lift



Rotating Top



Different Sized Platforms/Bases



Triple Scissor Lift with Round Top

Ball Transfer Top (Conveyers available)

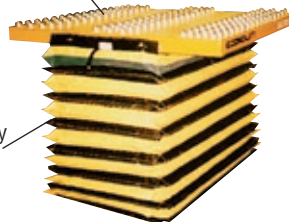

Bellow Safety Skirting

"V" Plate Double Scissor Lift



Movable Top

Double Scissor Lift

